



Thermo Scientific Antaris MX
FT-NIR Process Analyzer

The answer

to today's process
analytical challenges

Thermo
SCIENTIFIC

Antaris process capabilities

Improve product quality and manufacturing efficiency with the Thermo Scientific™ Antaris™ MX FT-NIR analyzer. It provides data at each critical point in your process and is linked through platform consistency and true integration.

The Antaris MX FT-NIR process analyzer is the robust solution for on-line monitoring and control of your manufacturing. Designed for production environments, this fiber-optic-based FT-NIR spectrometer allows you to remotely monitor multiple sampling points in your process simultaneously using a single instrument. Redundancy and true temporal data give you the real-time answers you need to respond to process deviations. System reliability, performance, and connectivity to other Antaris analyzers provide a significant return on your investment:

- Obtain faster feedback on your process
- Improve product quality
- Lower operating costs
- Increase product yields
- Increase process efficiency

All at a very low cost of operation and ownership

Fast, Reliable Answers

Wherever the analytical need in your process, the Antaris MX analyzer offers real-time solutions. From raw materials to reaction monitoring, near-infrared (NIR) measurements provide reliable information about your product quality and processes. Manual fiber optic sampling or probes interfaced with manufacturing equipment deliver instant feedback to optimize your production output. The Antaris MX analyzer can also be automated to provide simultaneous, multi-point sampling when placed at critical points in your manufacturing. Data collected in seconds is relayed to your manufacturing control module, resulting in a fast response time to out-of-standard conditions.

Built for Process

Manufacturing sites place different demands on equipment, from environmental conditions and data requirements to operator training and reliability standards. The Antaris MX analyzer has been developed with traceability to these factory requirements and is suited to meet challenging work conditions. We understand that equipment designed for the laboratory does not belong in the plant. The Antaris MX process analyzer combines reproducibility, reliability and suitability for answering today's analytical challenges.



Unrivaled near-infrared technology

for online monitoring

The Thermo Scientific™ ParaLux™ sample and reference illumination is an optimized multi-channel monitoring technology available for critical real-time analysis.

The Antaris MX ParaLux system provides:

- Simultaneous multi-point data collection
- No moving parts
- No channel switching time
- Continuous internal referencing (backgrounds)

True Simultaneous Multi-point Monitoring

The Antaris MX analyzer is available in two- or four-channel formats for on-line process analysis. It is the only NIR analyzer featuring accurate simultaneous measurements of up to four points. No need to switch channels that cause time delays with true time-aligned data, especially for highly dynamic processes. Eliminate lag time between measurement, decision, and response and you remove uncertainty due to time differences.

Simultaneous multi-point measurements allow you to:

- Plan for redundancy
- Measure and control processes that change quickly
- Reduce costs per measurement point over single channel

Unrivaled Stability and Simplicity

The ParaLux system self-references across all channels so background collections do not require a dedicated channel or disengaging the probe for unequalled stability. Uptime of your process is assured and repeatability is maximized.

Reliable System Design

ParaLux multiplexing uses no mechanical switching, completely eliminating potential variability in alignment, lag times between sample points, and the potential for mechanical failure. The ParaLux system samples any or all points on demand, at the same time. No moving parts translates to higher uptime.

Lower Detection Limits

The ParaLux system uses more photons per unit area than traditional multiplexing optical systems. The result is higher sensitivity to analytes, high precision, and shorter collection times to achieve excellent signal-to-noise.

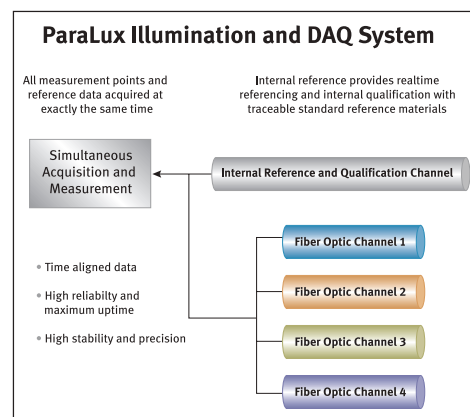

Migration from the Lab to Production Processes

Through a powerful combination of design, manufacturing techniques, and demanding specifications, the calibration transfer concept pioneered on the Antaris analyzer line changed the expectations for calibration performance from system to system.

- Proven optical design with permanent alignment provides unsurpassed stability
- Internal and real-time diagnostics assure in-specification function and performance

- Precise instrument matching assures reliable method transfer to other Antaris systems
- Control of external factors
 - Internal background handling on all sampling techniques
 - Variational standards and correction algorithms correct for fiber differences
- Develop routine or automated measurement methods using Thermo Scientific™ RESULT™ software workflows

The Antaris process analyzer line provides platform and performance continuity with Antaris and Antaris II systems.

Antaris MX FT-NIR process analyzer

The Antaris MX process fiber optic system provides remote sampling for raw material identification and characterization, quality measurements, and sample component analysis.

At Line

Ideal for the pharmaceutical and chemical industries, the Antaris MX fiber optic system allows measurements to be performed at the receiving dock or storage warehouse. The system is compatible with the Thermo Scientific™ SabIR™ hand-held diffuse reflectance probe that can analyze samples directly or indirectly through packaging materials. Operation is controlled through RESULT software workflows that control data collection, prediction, decision-making, reporting, and archival without operator dependence. The analyzer is internally self-referencing, further simplifying operation. Its small footprint makes it ideal for mobile analysis.



Integration with Enterprise Tracking and Data Systems

The Antaris MX analyzer provides excellent compatibility with material identification and inventory-tracking systems. The analyzer can be configured with a push-button software interface, using input from bar code and RFID systems capable of providing text input from encoded labeling. The Antaris MX can make pass/fail decisions without human input, making screening operations faster and reducing the possibility for human error. Data and reports can also be linked to LIMS and manufacturing planning systems.

Online

Ideal for placement in control rooms or non-hazardous environments, the Antaris MX analyzer allows measurement of multiple process points simultaneously. The Antaris I/O controller is available in a DIN or rack-mountable configuration for communication with process control systems using OPC, 4–20 mA and/or digital I/O. Antaris MX process suitability:

- Manual field use
- Raw materials
- Process monitoring
- Mobile analysis



Antaris MX analyzer with process-rated reflection probe



The Antaris MX analyzer can be configured with up to two trigger-based sampling probes for optimized switching between different sample types in a manufacturing setting.

Communications and control

RESULT software integrates the Antaris MX process analyzer into the production environment by relaying measurement data to real-time trend displays for simple monitoring, or to report data to control systems for closed-loop strategies.

RESULT software provides industry-standard OPC communications to output data and receive instructions for advanced control strategies. The Antaris integrated I/O controller provides analog and digital inputs and outputs of critical measurement data or signals to allow communication between RESULT software and the plant control systems. This integrated system maximizes performance and reduces implementation costs.

Antaris integrated communications allow:

- Connection to DSC/SCADA
- Remote Start/Stop
- Multiple input and output channels facilitate full control

Process I/O options include:

- Integrated PC
- Hazardous-zone rated computing and input devices
- RESULT OPC Server
 - Allows process communication via industrial Ethernet
 - Flexible communication and control for updated or new control systems
- Integrated Antaris I/O controller – available with:
 - 4 and 8 channel configurations
 - Digital I/O
 - 4–20 mA I/O

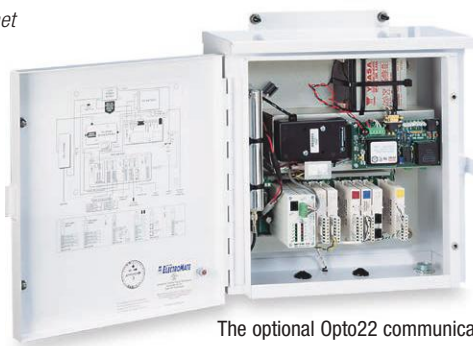
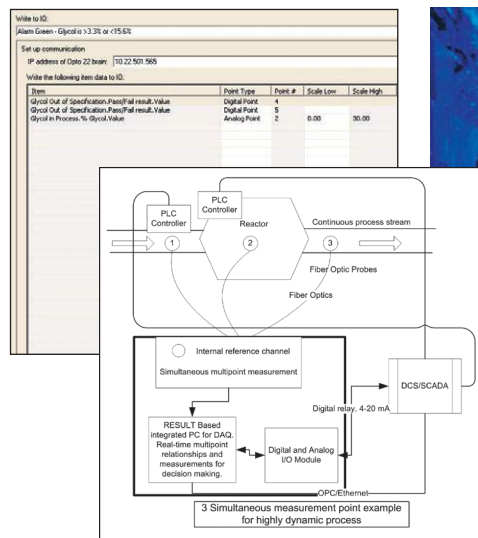

The optional Opto22 communications controller provides a fully integrated input/output solution for a wide range of analog and digital I/O signals

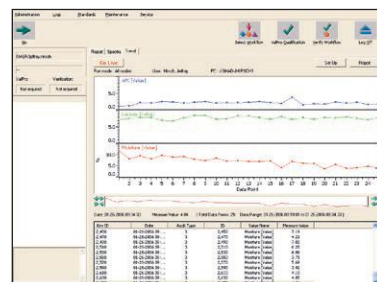

RESULT software supports multi-component trending for process monitoring and control

Cost-Effective and Simplified Regulatory Compliance

The Thermo Scientific™ ValPro™ system qualification package is a combination of documentation, testing workflows, traceable standard reference materials, and certified qualification services that facilitate the qualification steps of validation and routine performance verification.

- Tools to achieve 21 CFR Part 11 compliance including digital signatures, an audit trail and password security
- Automatically perform United States Pharmacopoeia (USP) and European Pharmacopoeia (PhEur) recommended qualification (OQ) tests

- Internal validation wheel with NIST-traceable, calibrated and serialized standards combined with a dedicated internal reference location allows for verification of the analyzers' performance at any time even while the process is running.
- External NIST-traceable, calibrated and serialized reflectance standards for wavelength accuracy and photometric linearity testing
- Flexibility to accommodate user-defined tests



Method development and transfer solutions

RESULT with Thermo Scientific™ TQ Analyst™ chemometric model development software provide powerful calibration diagnostic and transfer tools to solve industrial analytical challenges.

Method Deployment with RESULT

RESULT software is a dedicated analysis package developed for both routine and process analysis. Whether your application is at-line, on-line, in-line, or in development, RESULT software addresses your needs for:

- Method development and transfer using workflows and models to completely control system use and output, minimizing training requirements and simplifying user support
- Operational setup using an administration mode for privilege control, SOP, and workflow assignment customized for each user
- System and data security through password protected login, automatic audit trail generation, digital signature and tamper-proof reports
- Routine analysis using workflows for single push button, automated analysis by operators following on-screen instructions
- Automated process analysis for continuous and simultaneous, in-line monitoring of multiple components and multiple sampling points

Calibration Development and Optimization Tools

The calibration model optimization process is easy using TQ Analyst's unique method development wizards combined with interactive, visual diagnostic tools. Powerful, yet simple-to-use diagnostic plots and tools allow even the analytical beginner to quickly develop robust and high-performance models. TQ Analyst software incorporates advanced development and diagnostic tools for generating prediction models optimized for routine analysis, including:

- Method development wizards with artificial intelligence
- Statistical measurements including a performance index
- Principal Component Analysis (PCA) displayed in both 2D and 3D scores plots
- Leverage vs. Studentized Residual
- Spectrum Outlier diagnostic plots
- PRESS plot

Calibration Transfer Tools

TQ Analyst software was designed for seamless calibration transfer between instruments at different locations using portable and digitally signed methods for easy integrity verification. The software's interface, utilities, and diagnostics facilitate easy transfer of methods from other software packages. Method transfer between instruments using different sampling techniques and accessories can also present unique challenges to accurate and robust method transfer. These differences can be difficult to control and negatively affect your calibration transfer, for example from a laboratory to an on-line spectrometer. Variational standards is a feature in TQ Analyst software that aids in method transfer when environmental or sampling differences present challenges to method transfer.

Variational standards allow environmental and sampling factors to be excluded to correct for sources of spectral variation not in the calibration model. These factors include:

- Differences in fiber optics and process probes
- Sample temperature
- Sampling density, particle size
- Humidity
- Sampling technique, such as liquid transmission cell vs. transmission fiber optic probe

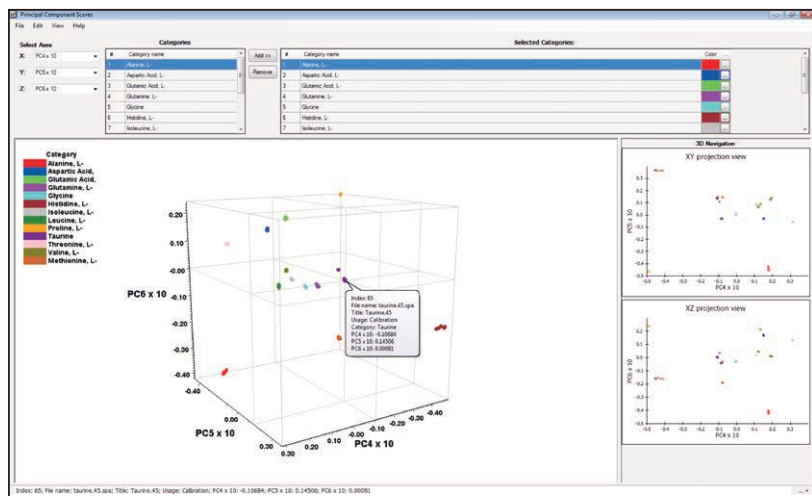

The 3D Principal Component (PC) scores display helps the developer optimize both identification and PLS models by visualizing inter- and intra-class or category (PLS) distributions. This interactive PC plot helps investigate sources of spectral variation through manipulating, zooming and displaying sample specific information in the 3D cube.



Fiber optic probe solutions

We offer a complete line of industry-tested fiber optic cable and probe configurations to provide the right mix of performance and protection.



Comprehensive Selection

The NIR probe sample interface is critical to the success of any NIR method. To develop accurate and robust test methods, the probe design must be compatible with sample morphology, turbidity, transmissivity, and reflectivity. A fiber optic probe that provides sufficient sample illumination and sampling area can mean the difference between a good and poor method performance. We provide a variety of probes that are optimized for sample and equipment interfacing, including probes for specific processes such as drying and fermentation monitoring. Our team of applications experts can help you choose the right fiber optics and probe for your task.

Tailored Performance

Our probes provide rugged, long-term performance using a proprietary sapphire window-to-metal seal capability. The probes are available in 316L Stainless Steel, Hastelloy®, or other materials based on application-specific needs and engineering requirements. Probes are available for operation at up to 300 °C and at 3000 or 5000 PSI. We offer a wide variety of probes for:

- Diffuse Reflectance
- Transmission
- Transflectance
- Multi-mode

Flange fittings for probe mounting are available, including:

- Tri-Clamp
- Ingold
- Bolt-on
- Swagelok® couplings

Fiber optic cables come standard with low-OH single or microbundle configurations and are protected by stainless steel, PVC or silicone jacketing. Probes include a base fiber length of 3 meters unless otherwise specified.

Specialty Probes

We also offer a series of specialty probes proven for specific applications, including:

Dual Mode Transflectance/ Reflectance Probe

This sampling probe combines reflectance and transflectance sampling in a single probe. This is optimal for sampling of processes such as fermentation, recrystallization, and slurry processes where the optical characteristics of the sample change significantly.

For example, use transflectance at early stages, when the material is relatively transparent. At the high particulate stage later in the process, use reflectance sampling. When this probe is used with the Antaris process analyzers and the ParaLux optical system, the analyzer can be programmed to automatically detect the switchover point (transparent vs. particulate stage) and collect data in the most suitable sampling mode.

Retractable Probe System

This sampling system represents a breakthrough in probe technology. It allows automatic insertion and removal of the probe via a standard relay connected to pneumatic control. This probe can be automatically purged internally to remove any sample crust from the probe window before a measurement is taken. The probe is also available with a side-facing window that can be wiped clean when automatically withdrawn from the sampling point and then reinserted.

The probe housing includes an optional wash station for automatic water or solvent rinsing of the probe, eliminating operator risk of exposure to dangerous sample material.

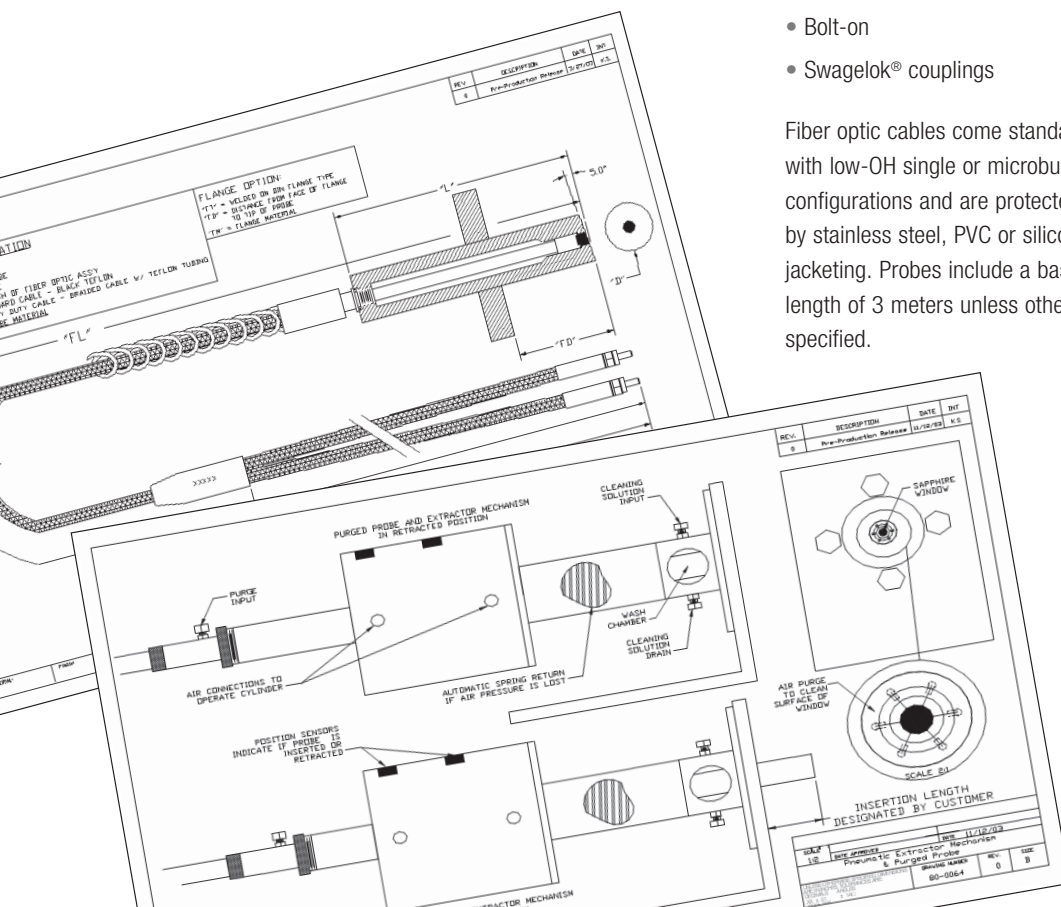

About the Antaris Line of Analyzers



Solving industry's analytical challenges begins by bringing the right tools to the job site for task suitability. We have combined our decades of spectroscopy experience with the knowledge of experts and everyday users to design a range of NIR analyzers that set new industry standards.

Our cross-platform elements in software, validation tools, methodology, support, and implementation make it easy to incorporate NIR analysis into your workflow. The Antaris product line connects the lab and the factory in ways that improve plant efficiency, reduce waste, and decrease downtime of your production line. We support our Antaris instruments with a full suite of services that keep your maintenance costs low and your productivity high.

Our Pledge of Support: A Fundamental Analyzer Requirement

The Antaris analyzer product family is backed by our worldwide applications and process support team. With dedicated support for most countries and regions around the world, our customer support organization is the best in the industry. We provide:

- **Applications Assistance**
- **Qualification Support**
- **Preventive Maintenance**
- **24/7 Services**

We offer product and customer services tailored to your NIR analyzer and process analysis. Let us recommend a support configuration, or ask us how we can customize these services specifically to your requirements:

1 Feasibility and Site Survey

We will work with you to evaluate the feasibility of near-infrared analysis as a solution to your process challenge. A Thermo Scientific NIR specialist will visit your intended use site to gather key information related to process analyzer integration and the necessary components, services, and preparations. We will provide a thorough proposal to ensure a smooth implementation.

2 Installation

Our certified field-service engineers ensure proper installation and operation of the analyzer. Prior to installation, we provide a site-readiness form to synchronize installation preparedness between your site and our engineers.

3 Qualification Services

We offer a full line of installation and operation qualification services and annual requalification services, which can be used in conjunction with the ValPro system, to demonstrate proper performance and suitability.

4 Training

Our team of Antaris support specialists can provide:

- **On-site or factory-based training on the use of the system**
- **Customized training to ready your staff or plant personnel**
- **Service training and certification to your plant personnel**

5 Method Development Services

If you do not have the time or resources to model your process parameters using near-infrared, let us provide calibration services for you:

- **Method Development**
- **Maintenance**
- **Transfer Services**

6 Repair and Technical Support Services

From depot repair to critical support, our services can provide 24/7 coverage to meet your instrument uptime requirements.

www.thermoscientific.com

©2013 Thermo Fisher Scientific Inc. All rights reserved. Hastelloy is a registered trademark of Haynes International, Inc. Swagelok is registered trademark of Swagelok Company. ISO is a trademark of the International Standards Organization. All other trademarks are the property of Thermo Fisher Scientific and its subsidiaries. Specifications, terms and pricing are subject to change. Not all products are available in all countries. Please consult your local sales representative for details.

Africa +43 1 333 50 34 0
Australia +61 3 9757 4300
Austria +43 810 282 206
Belgium +32 53 73 42 41
Canada +1 800 530 8447
China +86 21 6865 4588

Denmark +45 70 23 62 60
Europe-Other +43 1 333 50 34 0
Finland/Norway/Sweden
+46 8 556 468 00
France +33 1 60 92 48 00
Germany +49 6103 408 1014

India +91 22 6742 9494
Italy +39 02 950 591
Japan +81 45 453 9100
Latin America +1 561 688 8700
Middle East +43 1 333 50 34 0
Netherlands +31 76 579 55 55

New Zealand +64 9 980 6700
Russia/CIS +43 1 333 50 34 0
Spain +34 914 845 965
Switzerland +41 61 716 77 00
UK +44 1442 233555
USA +1 800 532 4752



Thermo
SCIENTIFIC

Part of Thermo Fisher Scientific