

Universal on-line gas preparation and introduction system for isotope ratio MS

Thermo Scientific GasBench Plus System

The Thermo Scientific™ GasBench Plus System provides a robust solution for high precision on-line isotope and molecular ratio determination of gaseous samples via headspace sampling. This includes applications in water equilibration, carbonates, and atmospheric gases (e.g. CO₂, O₂/N₂). The technology features:

- High precision analysis through multiple loop injection
- Automation driven by Thermo Scientific™ Qtegra™ Intelligent Scientific Data Solution (ISDS) Software for high sample throughput including significantly improved data reduction for all applications
- Unattended sample preparation and analysis supported by Thermo Scientific™ TriPlus™ RSH SMART Autosampler
- Enhanced laboratory efficiency through Qtegra ISDS Software driven workflow automation
- Low sample consumption delivering high sensitivity results
- GC separation of pure analyte from gas mixtures
- Automatic range recognition and auto-dilution allowing largest dynamic range of sample size
- High flexibility to serve diverse applications



The GasBench Plus System provides high quality analytical results under continuous flow IRMS operation. The sample gas is entrained in He, which allows GC separation and facilitates fractionation-free viscous flow transport of the sample aliquots. The sample analysis workflow is driven by Qtegra ISDS Software and enhanced by the automation capabilities of TriPlus RSH SMART Autosampler. For air measurements, GC separation and blanking mode allow for clean chromatograms and better defined analyte peaks.

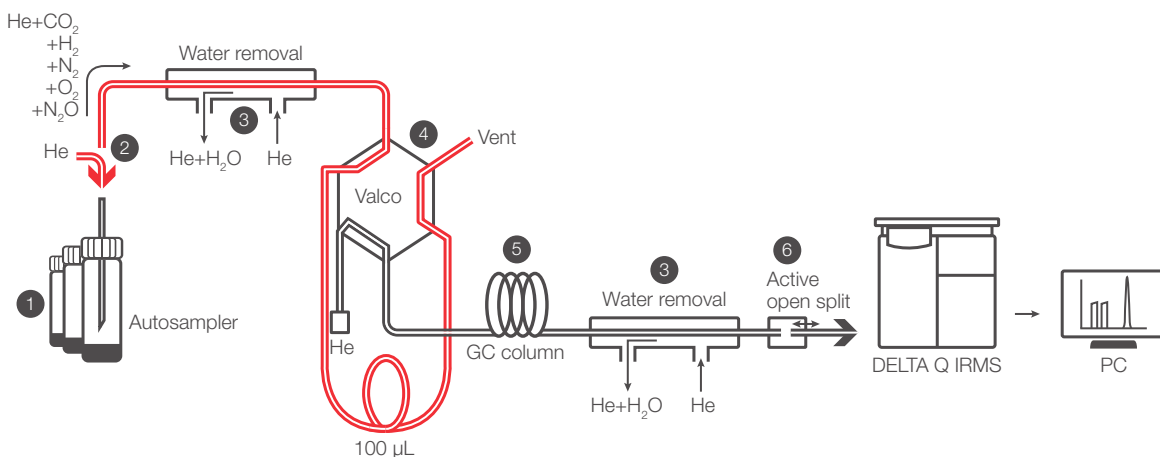

Figure 1. The GasBench Plus System Workflow schematics

The GasBench Plus System consists of a user programmable TriPlus RSH SMART Autosampler (1), a gas sampling system (2), a maintenance-free water removal system (3), a loop injection system (4), an isothermal gas chromatograph (GC) (5), an active open split interface or Thermo Scientific™ ConFlo IV Universal Interface (6), a reference gas injection system with three reference ports (7), and one or two optional LN2 traps for cryofocusing.

The TriPlus RSH SMART Autosampler offers exceptional precision, flexibility, and productivity in a robotic sample-handling solution, available in two models with a different level of automation:

- TriPlus RSH SMART Autosampler Standard allows switching the injection tool by Qtegra ISDS Software-guided quick and easy manual operation, providing a cost-effective solution
- TriPlus RSH SMART Autosampler Advanced performs the change of the injection tool automatically for unattended sequence with different sampling techniques and supporting the automation of Qtegra ISDS Software driven multi-step sample preparation workflows.

Modular Upgrade kits, tools and accessories are available for both the Standard and Advanced configurations to expand the sample handling capability, and transform any configuration into a multi-technique, multi-purpose robotic platform:

- GasBench Plus System tools allow for different needle configurations supporting denitrification, water equilibration, carbonate analysis, air measurements and atmospheric gases analysis.
- Accurate automation of a multitude of traditionally manual tasks is enabled by the Automatic Tool Change capability (ATC) and the integration of tools. The ATC enables a Qtegra ISDS Software LabBook (sequence) setup using different GasBench Plus System needle tools to perform flushing, acid dosing and sampling. The ability to exchange dedicated GasBench Plus System needle tools for different tasks provides accurate and highly precise sample preparation in a single, unattended sequence prior to automated sampling.
- GasBench Plus System in combination with TriPlus RSH SMART Autosampler supports heated and non-heated trays. A precisely thermostated sample tray is used for carbonates and water equilibration.
- Qtegra ISDS Software allows for automated sampling and sample preparation switching between trays including duplication of the same tray, offering highest flexibility and increasing the number of samples that can be processed.

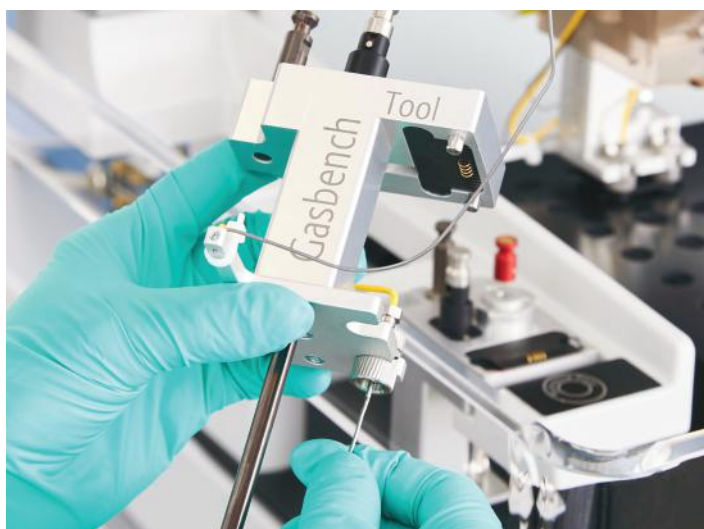

The gas sampling system includes a two-port needle which adds a gentle flow of He into the sample vial, thus diluting and displacing sample gas. Water is removed from the sample gas through diffusion traps.

The loop injector aliquots the sample gas onto the GC column, which separates the molecular species. The reference gas injection system allows accurate referencing of each sample aliquot to isotopic standards. The system is designed for unattended measurements with high throughput, ensuring high productivity and high reliability.

Integrated sample dilution

The GasBench Plus System offers integrated sample dilution capability controlled by Qtegra ISDS Software. If the signal height of the first sample peak exceeds a pre-defined threshold (e.g. 20 V), the diluter is activated resulting in a 3-fold reduction in signal height for the subsequent sample peaks. The dilution is performed in the open split, just before transfer into the ion source, eliminating any possible effects on the integrity of the sample gas or in the sample dilution of the ConFlo IV Universal Interface.

The integrated sample dilution capability allows analysis of samples that would normally be too large to be measured. This capability offers clear advantages in sample preparation, because it reduces the need for time-consuming weighing of samples, and it allows analysis of samples with unknown carbonate content (e.g. whole rock samples with carbonate cements).

PreCon integration and automation

For gas concentrations in the low ppm and ppb range, the Thermo Scientific™ PreCon™ Automated Trace Gas Pre-Concentrator gives access to the fully automated preparation and preconcentration of trace gases such as N₂O (330 ppb) and CH₄ (1.85 ppm) followed by cryogenic focusing in front of the GC column. The PreCon can be loaded manually or operated fully automatically using the TriPlus RSH SMART Autosampler for GasBench Plus System with the two-line needle for continuous sample transfer and large volume trays.



GasBench Plus System applications

The GasBench Plus System can be used for the isotopic characterization of CO₂, N₂O, O₂ or N₂ between 200 nmol and 20 μmol of total sample size. The CO₂ can be in the original gas sample (air or breath), be released through a preparation step (carbonates, DIC) or be added to the original liquid sample (water-CO₂ equilibration).

Due to the versatility of the GasBench Plus System the list of gas species, isotope ratios, and experiments that can be performed is constantly being extended. All applications and devices, including PreCon automated trace gas pre-concentrator, are driven by Qtegra ISDS Software allowing for unattended preparation and analysis of your samples including gas measurement switching.

The range of applications includes, but is not limited to:

- D/H in water through equilibration with H₂/Pt
- ¹⁸O/¹⁶O in water through equilibration with CO₂
- ¹⁸O/¹⁶O and ¹³C/¹²C from carbonates
- ¹³C/¹²C of dissolved inorganic carbon (DIC)
- ¹³C/¹²C and ¹⁸O/¹⁶O of CO₂ in air
- ¹⁸O/¹⁶O and ¹⁷O/¹⁶O of O₂ in air and water
- ¹⁵N/¹⁴N of N₂ in air

In combination with the PostCon Cryotrapping options or the PreCon:

- $^{13}\text{C}/^{12}\text{C}$ of CO_2 in air (sub-ambient concentrations)
- $^{15}\text{N}/^{14}\text{N}$ and $^{18}\text{O}/^{16}\text{O}$ of N_2O in air (300 ppb)
- $^{13}\text{C}/^{12}\text{C}$ of CH_4 in air (1.7 ppm)
- $^{15}\text{N}/^{14}\text{N}$ and $^{18}\text{O}/^{16}\text{O}$ of N_2O
- $^{15}\text{N}/^{14}\text{N}$ and $^{18}\text{O}/^{16}\text{O}$ of nitrate using denitrification techniques
- $^{15}\text{N}/^{14}\text{N}$ of N_2 from micro-preparation systems

Flexible design allows use with lasers and elemental analyzers:

- Sampling of CO_2 and SO_2 from laser combustions and decarbonation
- Post-combustion concentration of CO_2 , N_2 , SO_2 from elemental analyzers

GasBench Plus System workflows

1. $\text{H}_2/\text{H}_2\text{O}$ and $\text{CO}_2/\text{H}_2\text{O}$ equilibration for δD and $\delta^{18}\text{O}$ determination of water

The measurement of the D/H and $^{18}\text{O}/^{16}\text{O}$ ratios of water is used in applications ranging from studies of variations in natural isotope abundance in the hydrologic cycle, over authenticity control on beverages to metabolic studies using D- or ^{18}O -enriched tracers in humans and animals. This extreme range of sample types demands a flexible general-purpose analytical solution, which can provide high precision, high accuracy and high throughput analysis of D/H and $^{18}\text{O}/^{16}\text{O}$.

The aqueous samples are placed in 12 ml screw top vials using disposable pipettes. For H/D, a platinum catalyst is added. The vials are sealed with septa and all air is removed from the sample vials by an automated, Qtegra ISDS Software driven and TriPlus RSH SMART Autosampler-assisted flushing procedure which uses a mixture of either H_2 or CO_2 in Helium (He). The H_2 or CO_2 in the flushing He stream is used as equilibration gas. After the required equilibration time (D: 40 min, ^{18}O : 20 h at room temperature) the whole batch of samples is analyzed. The use of repetitive loop injection (1–2 min per replicate) achieves analytical precisions comparable to those from a dual inlet system. The whole process workflow from flushing, equilibration to the data reduction is assisted by one Qtegra ISDS Software LabBook method.

Workflow for analysis of hydrogen isotopes in water

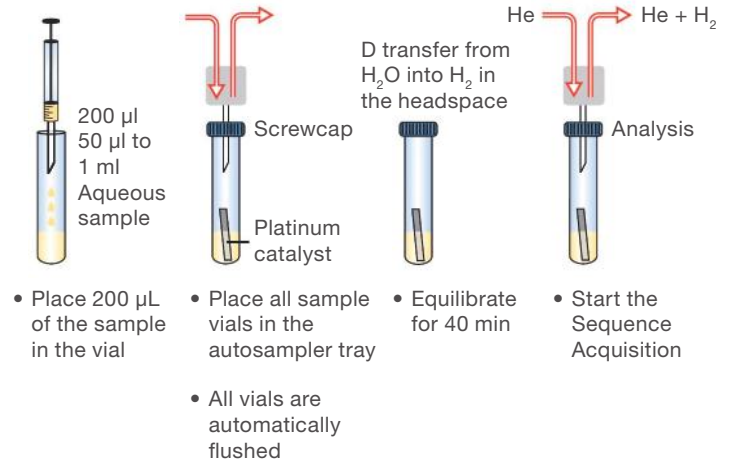
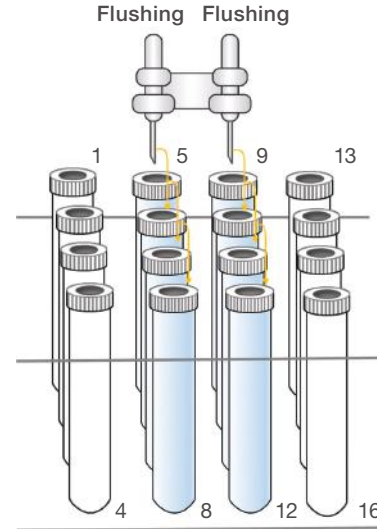
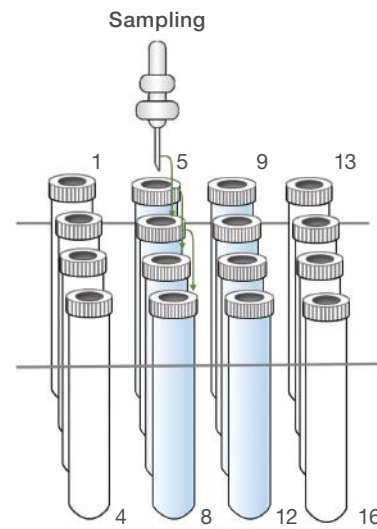

Figure 2. Automated sample preparation and measurement for hydrogen isotopes in water

Workflow for analysis of oxygen isotopes in water



GasBench Plus System Tool 1 – double flushing with CO_2 /helium



GasBench Plus System Tool 2 – sampling

Figure 3. Automated preparation and measurement for oxygen isotopes in water

2. $\delta^{18}\text{O}$ and $\delta^{13}\text{C}$ determination of carbonates

The GasBench Plus System in carbonate mode uses the principle of individual acid baths using a fully automated acid dosing system. The carbonate option contains a microliter pump that allows injection of anhydrous phosphoric acid into the sample vials. The double needle setup ensures identical reaction and analysis conditions for each sample. An overall precision of 0.08‰ for $\delta^{18}\text{O}$ and of 0.06‰ for $\delta^{13}\text{C}$ has been achieved.

Workflow for $\delta^{18}\text{O}$ and $\delta^{13}\text{C}$ determination of carbonates

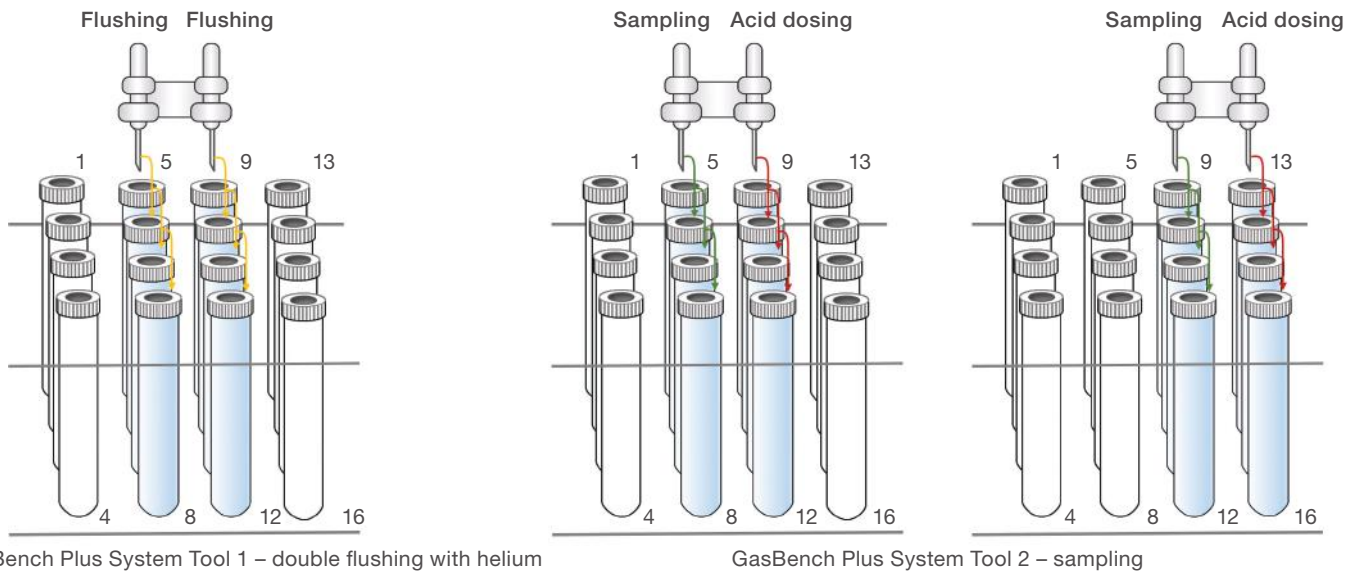

Figure 4. Automated sample preparation and measurement for carbon and oxygen isotopes in carbonates

3. Dissolved inorganic carbon

The GasBench Plus System provides a fast, reliable and accurate continuous flow method for DIC analysis, with guaranteed precision of <0.08‰. The risk of adsorption of CO_2 from air into the sea water during sample handling requires a different preparation of the sample vials. For example, 3 drops of phosphoric acid (ca. 3 μL) are placed in the empty vials. After sealing the vials with septa, all vials are automatically flushed with pure helium driven by Qtegra ISDS Software driven and assisted by the TriPlus RSH SMART Autosampler. The sea water samples are injected using gastight, disposable syringes. After a short reaction time, the CO_2 in the headspace of each vial is automatically analyzed using the same acquisition process as for all other GasBench Plus System applications.

Features and technical specifications:

- Carbonate reaction kit

The carbonate option contains a microliter pump that allows injection of anhydrous phosphoric acid into the sample vials and a dual needle array for dosing and sampling

- Single cryotrap

Trapping option with a single fused silica trap for sub ambient gas concentration (e.g. 100 ppm CO_2)

- Dual cryotrap (PostCon)

Trapping option with two traps, one 1/16" nickel-wire filled stainless steel trap for trapping ppm amounts of analyte from a fast He gas stream, and one fused silica trap for cryo-focusing onto the GC column head

- GasBench Plus System trays

Table 1. Thermo Scientific TriPlus RSH SMART Autosampler Trays for GasBench Plus System and PreCon

Tray description for TriPlus RSH SMART Autosampler Standard or Advanced	Vial size	Tray capacity
Thermostated sample tray for 12 ml vials	12 ml	96
Sample tray for 12 ml vials	12 ml	96
Sample tray for 20 ml vials	20 ml	77
Sample tray for 50 ml	50 ml	48
Sample tray for 100 ml	100 ml	20
Sample tray for 250 ml vials	250 ml	12
Extended sample tray for 12 ml vials	12 ml	290



Analytical performance

Table 2. External precision of isotope ratios C, O, H, using the Thermo Scientific GasBench Plus System with 12 mL vials (n=5), δ notation

Water equilibration (versus V-SMOW & SLAP) ¹			
500 μ l	as CO ₂	$\delta^{18}\text{O}$	$\leq 0.08\text{‰}$
200 μ l	as H ₂	$\delta^2\text{H}$	$\leq 2.0\text{‰}$
		$\delta^2\text{H}$	$\leq 0.5\text{‰}$ on raw data ¹
Carbonates			
100 μ g	as CO ₂	$\delta^{18}\text{O}$	$\leq 0.1\text{‰}$
		$\delta^{13}\text{C}$	$\leq 0.1\text{‰}$
Dissolved inorganic carbon, ocean water			
600 μ l	as CO ₂	$\delta^{13}\text{C}$	$\leq 0.08\text{‰}$
CO ₂ in air			
12 ml	as CO ₂	$\delta^{13}\text{C}$	$\leq 0.2\text{‰}$

1. V-SMOW & SLAP scaling: Based on IAEA recommendations all ¹⁸O and D analysis need to be based on V-SMOW and SLAP. For H₂/H₂O equilibration with platinum catalyst. This referencing results in a scale expansion of up to 4 times from the raw delta values to the final data, which equivalently decreases the precision of measurements.

On ¹⁸O determinations (CO₂/H₂O) this data processing also needs to be performed but the scaling factor usually is almost 1 and therefore has minor effect on the performance data.

Acceptance specification

During installation, the system performance of the GasBench Plus will be demonstrated with a mixture of CO₂ in He ($\geq 0.3\%$), to show an external precision of 0.08‰ or better for $\delta^{13}\text{C}$ and $\delta^{18}\text{O}$ (n=5).

A mixture of H₂ in He mixture ($\geq 1.0\%$) is used to show an external precision (n=5) of 2.0‰ or better for $\delta^2\text{H}$.

Installation requirement

Power: 230 V single phase, 8 A

Gases:

- He, better 99.999%
- CO₂, better 99.995%
- H₂, better 99.999%
- 0.3%–1% CO₂, (99.995%) in He (99.999%) for ¹⁸O water equilibration
- 1.0%–2.0% H₂ (99.999%) in He (99.999%) for ²H water equilibration

Weight:

- GasBench Plus System 14 kg
- Heated tray, TriPlus RSH SMART Autosampler and Baseplate 52 kg

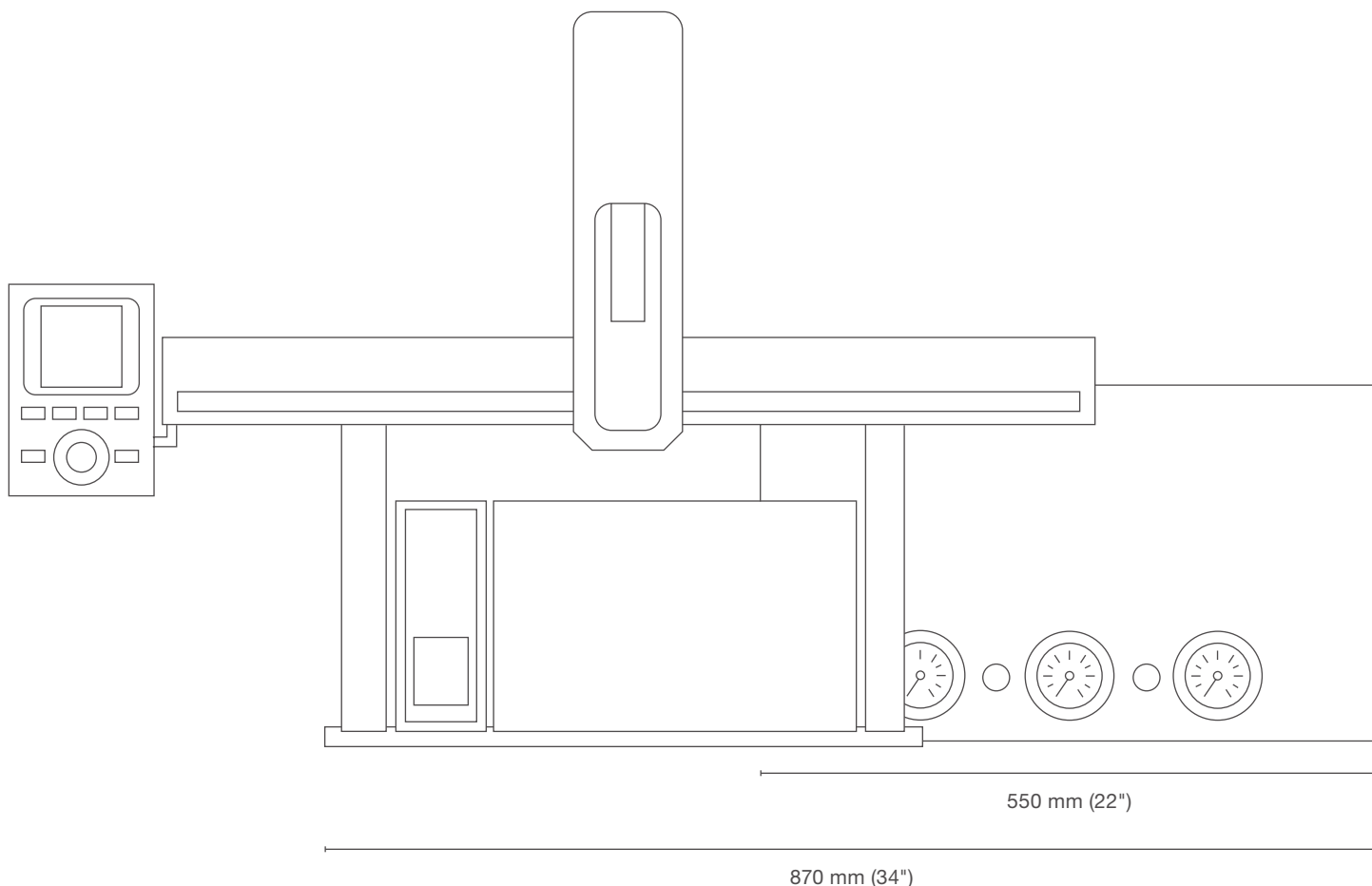

Figure 5. GasBench Plus System dimensions

Optional items:

- PoraPLOT Q capillary column for separation of N₂ and CO₂ (included in the standard GasBench Plus System)
- Carbonate kit with dual needle support, acid pump and needle, phosphoric acid for carbonate analysis
- Temperature stabilized tray with 96 x 12 mL vials for carbonate and water analysis
- Hydrophobic Pt catalyst sticks for H₂/H₂O equilibration
- 5Å PLOT capillary column for good chromatographic resolution and thus high precision isotopic measurements of the molecular components of air (N₂, O₂, Ar, CH₄, CO)
- Single cryo trap for trapping of trace gases from low He flow systems
- PostCon dual cold trap for trapping of trace gases from high He flow systems with subsequent cryo-focusing in the second trap

Find out more at thermofisher.com/irms