

CL17sc Colorimetric Chlorine Analyser

Applications

- Drinking water
- Wastewater
- Food and beverage
- Pharmaceutical
- Power
- Semiconductor
- Field use



The Next Standard in Chlorine Analysis

Built on a legacy of reliability in online chlorine analysis, the advanced design of the CL17sc reduces routine maintenance touch time and provides powerful diagnostic features and enhanced connectivity. The result is less hassle, minimised risk of data loss, and even more reliable information to empower your decision making.

Maintenance made easy

The CL17sc reduces your routine maintenance touch time with programmable alerts, simplified tubing replacement, and step-by-step maintenance instructions.

Peace of mind through comprehensive diagnostics

With upgraded features like a flow meter, colorimeter window, multi-colour status light, and predictive diagnostic software, you know your instrument is operating as intended.

Expanded connectivity. Increased flexibility.

By pairing the CL17sc with Hach's SC controller platform, your options increase significantly: internal data logging; external analogue and digital communication alternatives; and multi-parameter instrument flexibility.

The CL17sc is compliant with US EPA regulation 40 CFR 141.74. Both Method 4500-CL G and Method 334.0 can be used for measuring residual chlorine in drinking water.



Be Right™

Technical Data*

Measuring range	0 - 10 mg/L free or total residual chlorine	Reagent consumption	0.5 L of buffer solution and 0.5 L of indicator solution in 31 days
Accuracy	± 5% or ± 0.04 mg/L (whichever is greater) from 0 - 5 mg/L Cl ₂ ± 10% from 5 - 10 mg/L Cl ₂	Certifications	CE compliant with: EN 61326-1, CISPR 11, EN 50581 ACMA RCM South Korea KC Certificate North America: FCC Supplier's Declaration of Conformance, IEC/EN 60529, ICES-003
Detection limit	0.03 mg/L	Light source	LED, measurement at 510 nm, 1 cm light pathlength
Cycle time	2.5 minutes	Enclosure waterproof rating	IP66
Inlet pressure	0.3 - 5.2 bar supplied to Y-strainer 0.1 - 0.3 bar supplied to analyser	Mounting	Wall mount
Inlet	¼-inch OD polyethylene tube, quick-disconnect fitting	Power requirements (Voltage)	12 VDC, 400 mA maximum (supplied by the controller)
Drain	½-inch ID flexible hose	Dimensions (H x W x D)	342 mm x 329 mm x 177 mm
Air purge	Optional with 3/8-inch quick-connect fitting and tubing; 0.003 m ³ /min at 1.38 bar maximum	Weight	4.1 kg
Sample requirements	Y-strainer filtration with 40-mesh screen or higher		
Flow rate	60 - 200 mL/min through the instrument		
Sample temperature	5 - 40 °C		
Operating temperature range	5 - 40 °C		
Operating humidity	0 - 90% relative humidity, non-condensing		
Interferences	Other oxidising agents such as bromide, chlorine dioxide, permanganate, and ozone will cause a positive interference. Hardness must not exceed 1,000 mg/L CaCO ₃ .		

**Subject to change without notice.*

Principle of Operation

The CL17sc Colorimetric Chlorine Analyser has three operating components:

- A linear peristaltic pump to precisely control the volume of incoming samples and reagents
- A colorimeter
- Indicator and buffer solutions

A zero reference point is established at the beginning of the cycle by measuring blank absorbance. (This compensates for the sample's colour intensity and turbidity before the chlorine measurement is made.) Indicator and buffer solutions are then added to the sample while a magnetic stirrer mixes the solution and the sample changes colour. A colorimeter then measures the light transmitted through the sample. The measured colour intensity is compared to a reference standard. Finally, the sample cell is flushed with new sample so that the cycle can repeat every 2.5 minutes.

Dimensions

The CL17sc is designed to be wall-mounted with four ¼-inch screws. Adequate clearance must be left for plumbing and controller connection. The sample inlet connection is a ¼-inch quick-connect fitting and the drain connection is ½-inch ID flexible hose. The analyser receives power from connection to a Hach SC controller. (The analyser's cable is approximately 1.8 m in length.)

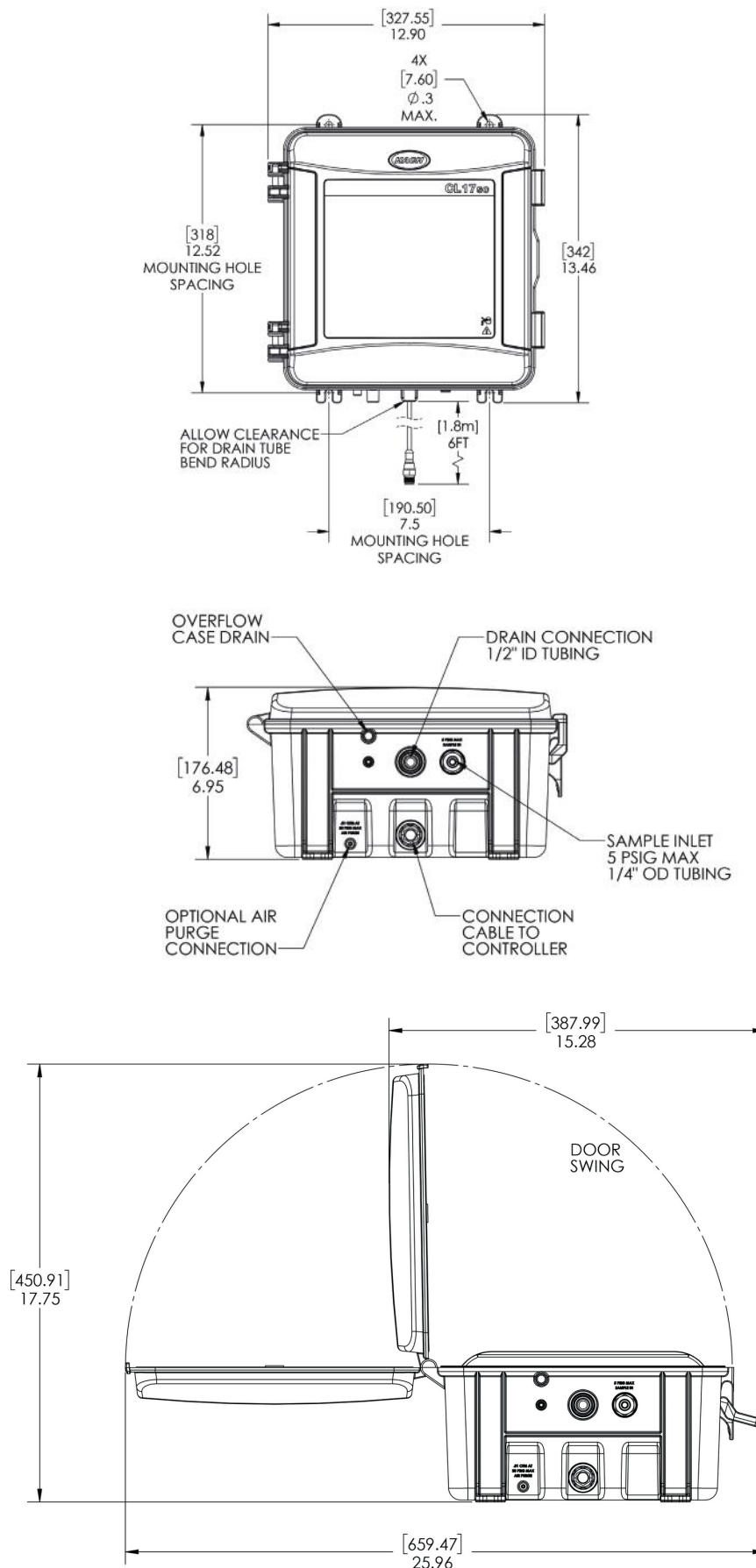

Order Information

Hach CL17sc Colorimetric Chlorine Analysers are shipped with an installation kit, user manual, and one month of reagents where noted. The user selects a standpipe installation kit or a pressure regulator installation kit at the time of purchase. Hach SC controllers are required for operation and are sold separately.

CL17sc Colorimetric Chlorine Analysers

- 8574400** CL17sc Colorimetric Chlorine Analyser with Standpipe Installation Kit, w/o Reagents
8574500 CL17sc Colorimetric Chlorine Analyser with Pressure Regulator Installation Kit, w/o Reagents

Accessories

- 8568200** CL17sc Calibration Verification Kit
8573200 CL17sc Calibration Verification Refill Kit
8560500 CL17sc Standpipe Installation Kit
8565700 CL17sc Pressure Regulator Installation Kit

Reagents and Consumables

- 8575000** CL17sc Tubing Kit (pre-assembled)
8573100 CL17sc Cell Cleaning Kit
2556900 Reagent Set, Chlorine, Free
2557000 Reagent Set, Chlorine, Total



This instrument connects to Claros, Hach's innovative Water Intelligence System. Claros allows you to seamlessly connect and manage instruments, data, and process – anywhere, anytime. The result is greater confidence in your data and improved efficiencies in your operations. To unlock the full potential of Claros, insist on Claros Enabled instruments.



With Hach Service, you have a global partner who understands your needs and cares about delivering timely, high-quality service you can trust. Our Service Team brings unique expertise to help you maximise instrument uptime, ensure data integrity, maintain operational stability, and reduce compliance risk.